

STORED ASSORTMENT



TECHVITAS

— Industrial Supply. Service. Consulting. —

Ball runner blocks and guide rails assortment

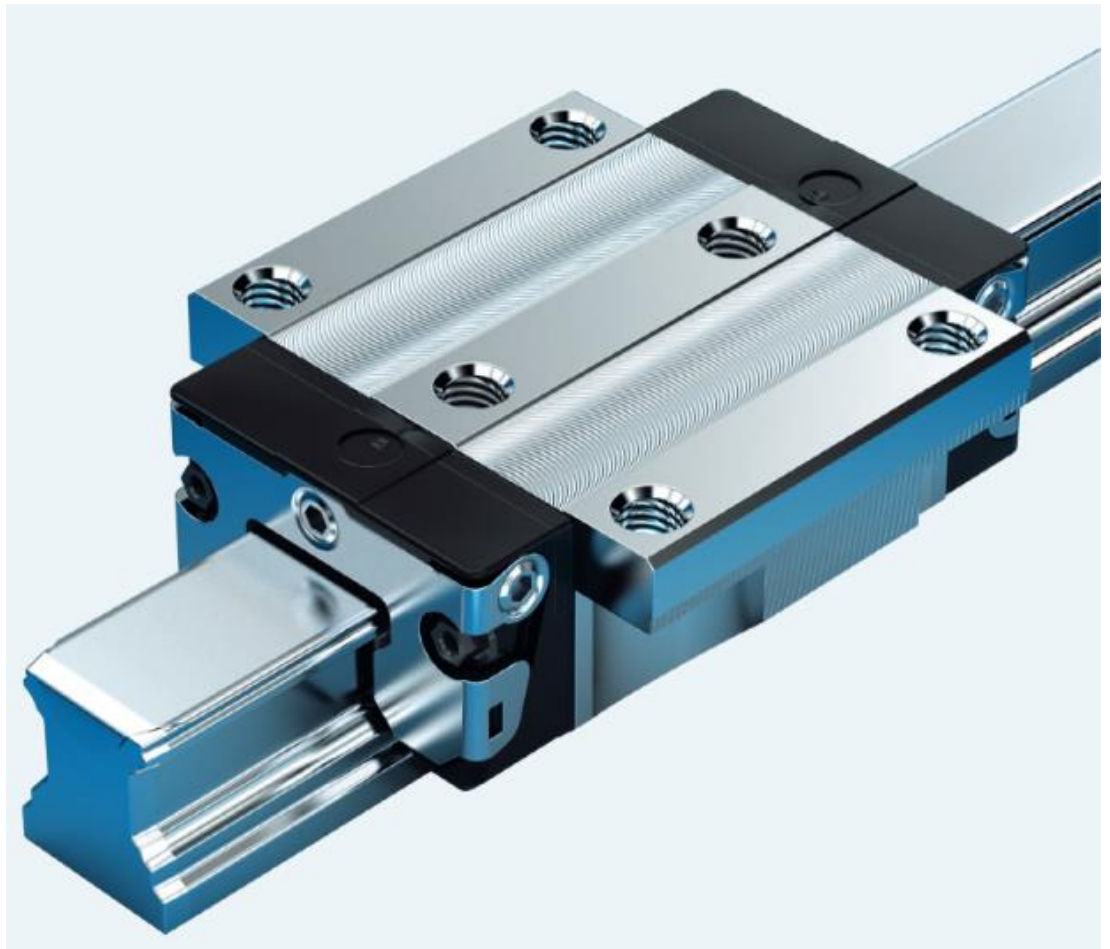

rexroth
A Bosch Company

The most popular ball runner blocks and guide rails

R1651
FNS



At Rexroth, we manufacture ball guide rails and ball runner blocks in ball raceways in particular so precisely that it is possible to interchange each individual element at any time. This means that you can combine them in any way you like within each accuracy class.

R1653
FLS



Highlights:

R1622
SNS



- The same high load capacities in all four main directions of loading;
- Very low noise level and best travel performance;

R1623
SLS



- Excellent dynamic characteristics:
 - Speed $V_{max} \leq 10$ m/s;
 - Acceleration $a_{max} = 500$ m/s².

R1669
SKN



- Limitless interchangeability; all guide rail versions can be combined with all runner block versions;
- Long-term lubrication over several years possible;

R1605
SNS



- 60 % weight saving with aluminum ball runner block (compared to the steel version);

e-catalog version

<https://goo.gl/D7zQy7>



Explanation of ball runner block codes

Type	Width	Length	Height	Code numbers
FNS	Flange	Normal	Standard height	R1651
FLS	Flange	Long	Standard height	R1653
SNS	Slimline	Normal	Standard height	R1622
SLS	Slimline	Long	Standard height	R1623
SKN	Slimline	Short	Low profile	R1669

Size	Code numbers
15	Mounted on size 15 guide rail 1
20	Mounted on size 20 guide rail 8
25	Mounted on size 25 guide rail 2
30	Mounted on size 30 guide rail 7
35	Mounted on size 35 guide rail 3
45	Mounted on size 45 guide rail 4

System preload	Code numbers
C0	Without preload (clearance) 9
C1	Moderate preload 1
C2	Average preload 2
C3	High preload 3

Accuracy class	Code numbers
N	Normal accuracy class 4
H	High accuracy class 3
P	Precise accuracy class 2
XP	Extra precise accuracy class 8

Seal	Code numbers
SS	Standard seal 20
LS	Low-friction seals 21
DS	Double-lipped seal 2Z

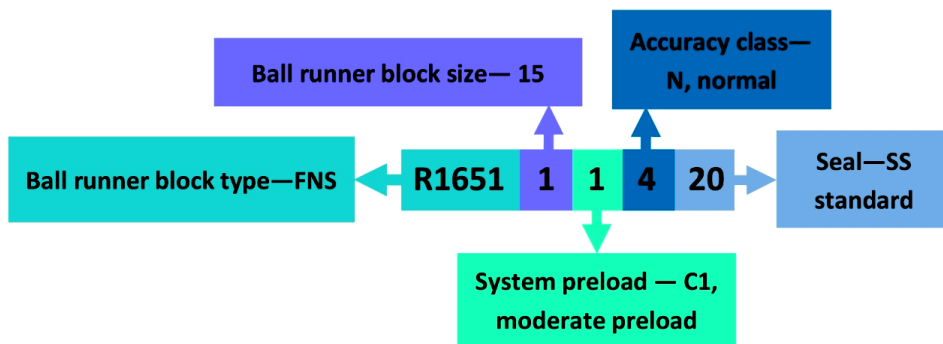

The most popular ball runner blocks

	CODE	DESCRIPTION
SIZE 15	R165111420	B.RUNNER BLOCK CS KWD-015-FNS-C1-N-1
	R165311420	B.RUNNER BLOCK CS KWD-015-FLS-C1-N-1
	R162211420	B.RUNNER BLOCK CS KWD-015-SNS-C1-N-1
SIZE 20	R165181320	B.RUNNER BLOCK CS KWD-020-FNS-C1-H-1
	R16518132Z	B.RUNNER BLOCK CS KWD-020-FNS-C1-H-1
	R165381420	B.RUNNER BLOCK CS KWD-020-FLS-C1-N-1
	R162281320	B.RUNNER BLOCK CS KWD-020-SNS-C1-H-1
SIZE 25	R165121420	B.RUNNER BLOCK CS KWD-025-FNS-C1-N-1
	R16512142Z	B.RUNNER BLOCK CS KWD-025-FNS-C1-N-1
	R165122420	B.RUNNER BLOCK CS KWD-025-FNS-C2-N-1
	R16532142Z	B.RUNNER BLOCK CS KWD-025-FLS-C1-N-1
	R165321420	B.RUNNER BLOCK CS KWD-025-FLS-C1-N-1
	R16222142Z	B.RUNNER BLOCK CS KWD-025-SNS-C1-N-1
	R162221420	B.RUNNER BLOCK CS KWD-025-SNS-C1-N-1
	R162323820	B.RUNNER BLOCK CS KWD-025-SLS-C3-X-1
	R166621320	B.RUNNER BLOCK CS KWD-025-SKS-C1-H-1
	R167121320	B.RUNNER BLOCK CS KWD-025-BNS-C1-H-1
	R166922013*	B.RUNNER BLOCK CS KWC-025-SKN-C1-H-2 S
SIZE 30	R165171320	B.RUNNER BLOCK CS KWD-030-FNS-C1-H-1
	R165371420	B.RUNNER BLOCK CS KWD-030-FLS-C1-N-1
	R162271420	B.RUNNER BLOCK CS KWD-030-SNS-C1-N-1
SIZE 35	R165331420	B.RUNNER BLOCK CS KWD-035-FLS-C1-N-1
	R165331320	B.RUNNER BLOCK CS KWD-035-FLS-C1-H-1

** – special ball runner blocks for Homag machines.

Accessories

CODE	DESCRIPTION
R161912120	FRONT SEAL for 15 size ball runner blocks
R161982120	FRONT SEAL for 20 size ball runner blocks
R161922130	FRONT SEAL for 25 size ball runner blocks
R161972130	FRONT SEAL for 30 size ball runner blocks
R161932130	FRONT SEAL for 35 size ball runner blocks
R341603700	Dynalub 510, NLGI Category 2 lithium-based grease for linear motion systems.

The most popular guide rails



SNS economical ball guide rails with plastic mounting hole plugs.

Rails can be cut in Klaipeda warehouse according to customer specification, maximum length is 3836 mm.

Size 20 – 25 up to 5816 mm being available on request.

Size 30 – 35 up to 5836 mm being available on request.

	CODE	DESCRIPTION
SIZE 15	R160510431S	B.GUIDE RAIL CS KSA-015-SNS-N-MA-AK
SIZE 20	R160580431S	B.GUIDE RAIL CS KSA-020-SNS-N-MA-AK
SIZE 25	R160520431S	B.GUIDE RAIL CS KSA-025-SNS-N-MA-AK
SIZE 30	R160570431S	B.GUIDE RAIL CS KSA-030-SNS-N-MA-AK
SIZE 35	R160530431S	B.GUIDE RAIL CS KSA-035-SNS-N-MA-AK

S letter at the end of the code – UAB Techvitas stock rails.

HEAD OFFICE

Dubysos str. 66A, LT-94107, Klaipeda

Tel. +370 46 355494
Mob. tel. +370 699 03907
+370 650 42992
+370 652 10541

www.techvitas.com

Vilnius | +370 655 76803

Kaunas | +370 655 73316

Klaipeda | +370 699 03907

Siauliai | +370 656 56755

Panevezys | +370 699 85436

Utena | +370 650 37122

Kedainiai | +370 612 59594

Taurage | +370 656 67435

Silute | +370 656 31360

Riga | + 371 22 325 004

Tallinn | +372 5670 0702

Katowice | +48 3235 37524

Minsk | +375 44 794 1992

Kiev | +380 9561 74240

